

RCE-20

RAIL-CERTIFIED FANLESS COMPUTER

KEY BENEFITS

- ▶ Ultra compact rail embedded fanless computer
- ▶ EN50155 certified for rail vehicle applications
- ▶ Multiple serial and digital I/O with optional PoE
- ▶ Wide temperature range
- ▶ High shock and vibration resistance
- ▶ Powerful latest generation Atom® quad core processor



Compact, reliable, powerful, fanless rail computer with multiple I/O capabilities and optional PoE for camera connection. Rugged construction with wide temperature range, shock & vibration resistance and very small size provides a powerful computer for many rail vehicle applications.



SPECIFICATIONS

RCE-20	Rail-certified Fanless Computer
CPU	Atom E3845 Quad Core, 1.91GHz
Memory	2GB DDR3, expandable to 8GB
Storage	1 x 2.5" SATA SSD/HDD, optional removable tray 1 x mSATA
Graphics	On board HD graphics
Expansion	2 x Mini-PCIe sockets (including mSATA) 1 x SIM socket
LAN	2 x Gigabit LAN by Intel® I21 Port with optional PoE
I/O	4 x RS232/422/485 4 x USB 3.0 4 x isolated DI, 4 x isolated DO (RCE-200)
Power Input	6V to 36V, DC-in
Watchdog Timer	Reset: 1 to 255 sec./min. per step
Smart Management	Wake on LAN, PXE supported
HW Monitor	Monitoring temperature and voltages Auto throttling control when CPU overheats
Video	1 x DVI-I

RCE-20	Rail-certified Fanless Computer
Audio	1 x Speaker out
Operating System	Win 7/8, Linux
PSU	Optional 60W AC power adapter
Mounting	Wallmount by mounting bracket, DIN Rail Mount (Optional)
Dimensions	106mm W x 55mm H x 150mm D
Weight	2kg
Construction	Aluminium
Temperature	Operating: -20°C to 70°C (SSD) Storage: -40°C to 85°C
Humidity	5% to 95% Humidity, non-condensing
Relative Humidity	95% @ 70°C
Shock	50g, 11ms (SSD)
Vibration	1g, 5-500Hz (HDD)
Certification	CE, FCC, EN50155, EN 50121
Ordering Information	RCE-200: Atom E3845 quad core RCE-201: Atom E3845 quad core, PoE, 8 Isolated DIO

TECHNICAL DETAILS

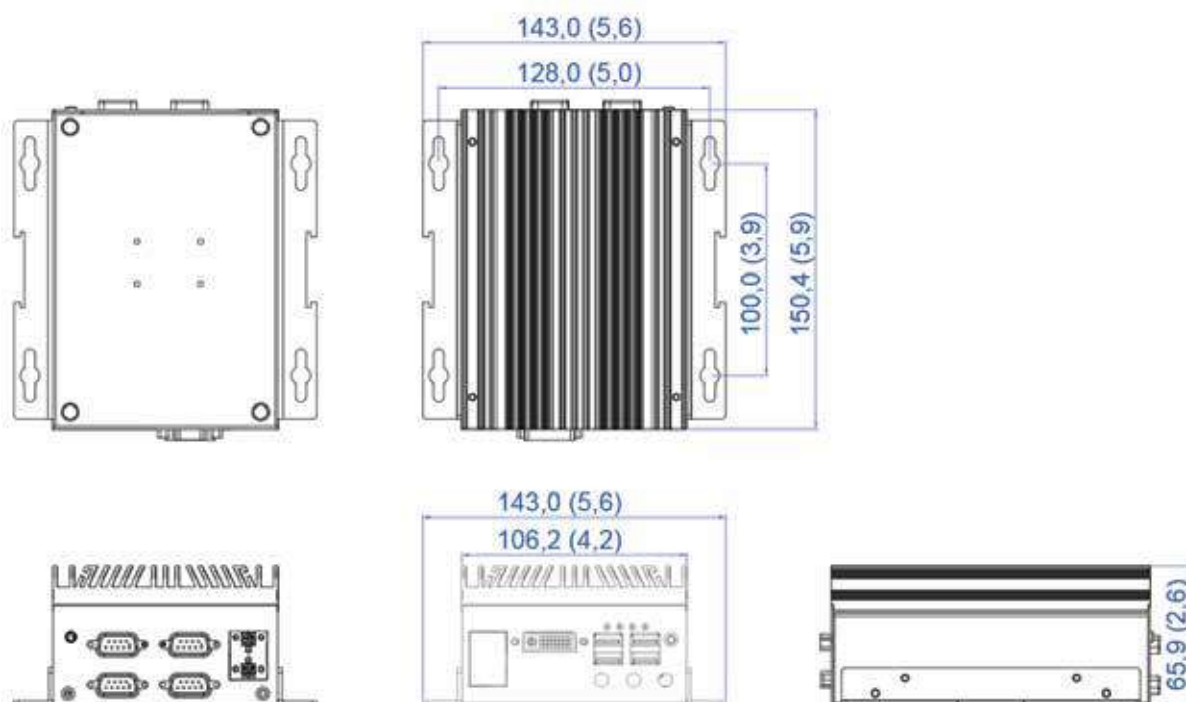

E&OE. Captec reserves the right to change specifications without notice.

CAPTEC

www.captec-group.com

EMEA Office

7 Whittle Avenue, Fareham
Hants, PO15 5SH, UK

T: +44 (0)1489 866 066

F: +44 (0)1489 866 088

E: sales@uk.captec-group.com

[in /company/captec](https://www.linkedin.com/company/captec)

North America Office

15 Saltzman Dr. Cambridge,
ON. N3H 4R7, Canada

T: +1 (519)650-4000

F: +1 (519)650-2000

E: sales@ca.captec-group.com

[@Captecgroup](https://twitter.com/Captecgroup)

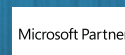

180717-1 © Captec Ltd. 2018 All rights reserved - All products and company names listed are trademarks or trade names of their respective companies

